

ENCORE[®] SERIES

OPERATING MANUAL

PN 54165

SELF-SERVICE INLINE CRUSTY BREAD MERCHANDISER

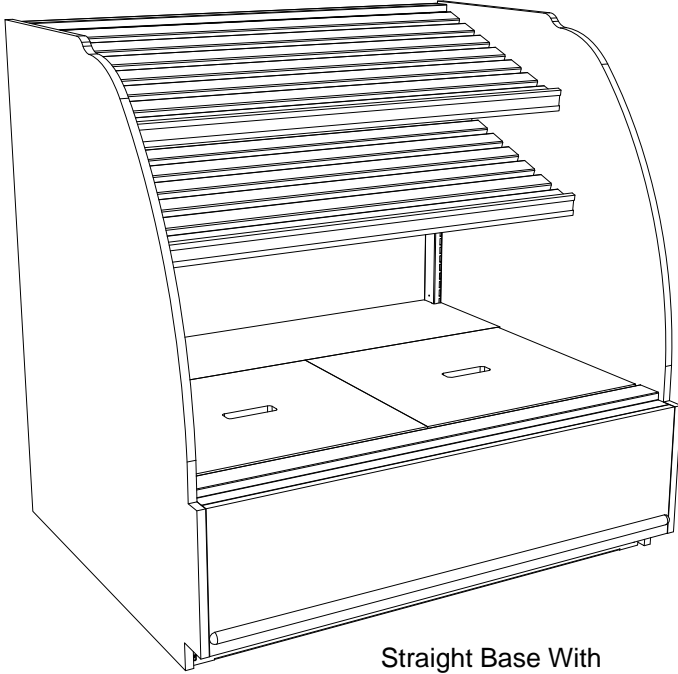

Straight Base With
Two Shelves

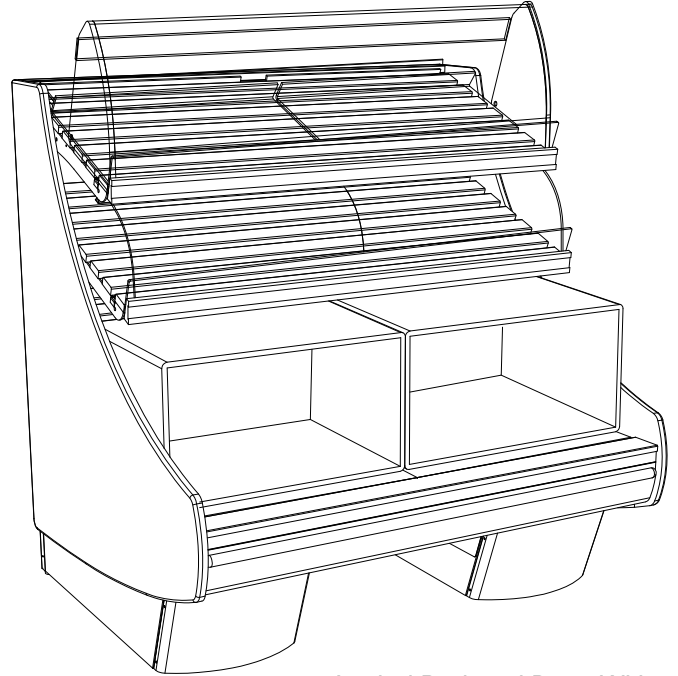

Angled Pedestal Base With
Two Shelves, Optional
Acrylic Bins and Baskets

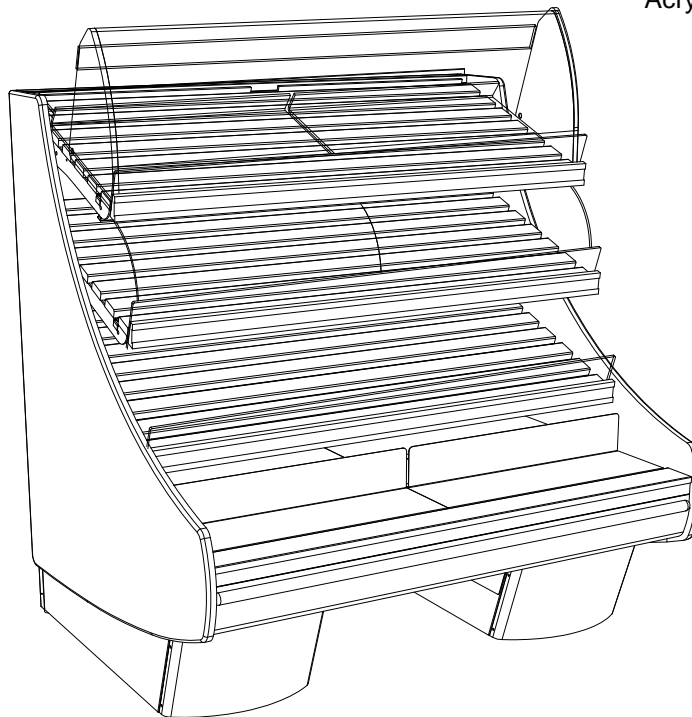

Angled Pedestal Base With Three Shelves, Product
Stop on Deck, and Optional Acrylic Bins

Model HVCB48, HVCB56, HVCB74*
*See Technical Information
Sheets for specific dimensions.



888 E. Porter Road · Muskegon, MI 49441 Phone: 231.798.8888 Fax: 231.798.4960 www.structuralconcepts.com

TABLE OF CONTENTS

OVERVIEW AND WARNINGS	3
REMOVAL FROM SKID	4
POSITIONING AND LEVELING UNIT	5
SHELF REMOVAL	6
LIGHTS (ACCESS AND REMOVAL)	7
CLEANING SCHEDULE - TO BE PERFORMED BY STORE PERSONNEL	8
TROUBLESHOOTING	9
SERIAL LABEL & LOCATION / TECHNICAL INFORMATION / ADD'L INFORMATION	10
STRUCTURAL CONCEPTS® WARRANTY	11
TECHNICAL SERVICE	12

OVERVIEW AND WARNINGS

OVERVIEW

- This Structural Concepts® Case is designed to merchandise packaged / unpackaged bakery products.
- This case should be installed and operated according to this Operating Manual to insure proper performance.
- This unit is designed for the display of products in ambient store conditions where temperatures and humidity are maintained at a maximum of 75°F / 24°C and 55% relative humidity.

This merchandiser is designed for the display of non-hazardous, packaged / unpackaged bakery products (per NSF Std. 2 – 1999).

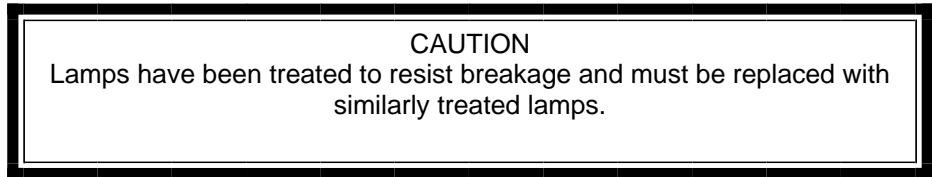
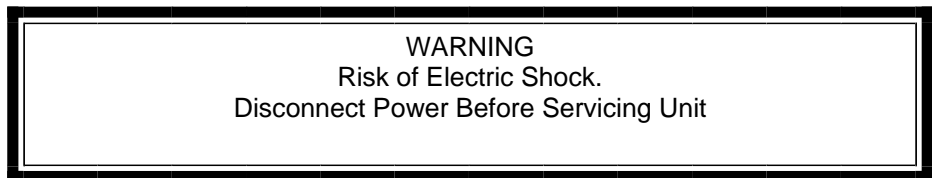
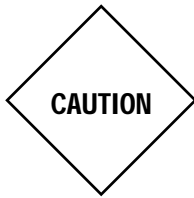

REMOVAL FROM SKID

1. Remove Unit From Skid

- Remove case from skid and place into proper position.
- To prevent damage, support case while sliding skid out from under case.
- *Note: Illustration at right reflects general outline of sample case and does not reflect any particular model or options).*

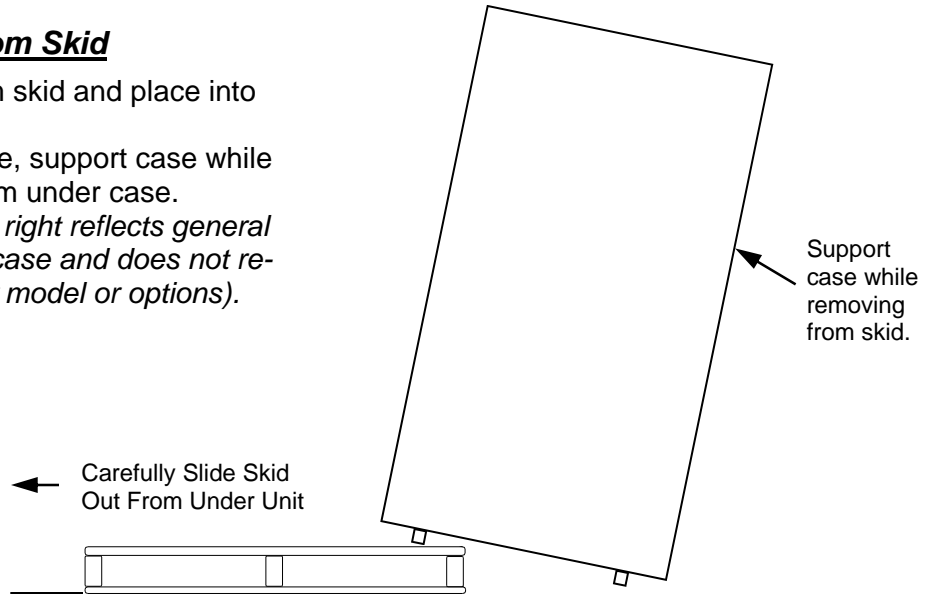

1. Positioning Case

- Before adjusting levelers, make certain that the case is in proper position.

2. Adjust Levelers

- After case is in proper position, adjust case so it is level and plumb (see illustration at right).
- You may need to remove front and/or rear Toe-Kick to access levelers.
- Use adjustable wrench to adjust leveler.
- See illustration and photos below.

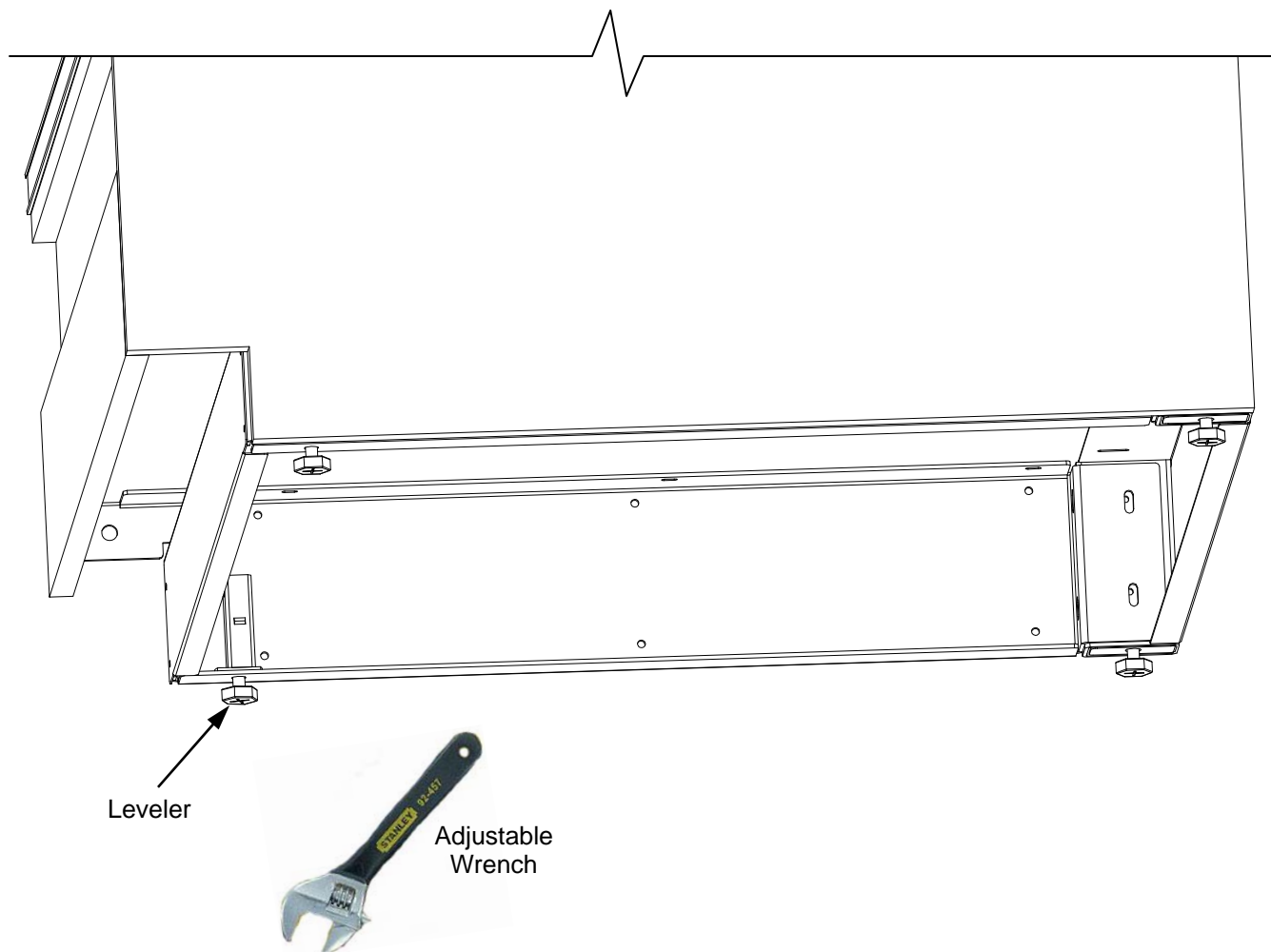

SHELF REMOVAL

Removing the Shelves

These cases are designed with adjustable shelves and optional wicker baskets. To adjust or to remove, follow these instructions.

1. Remove the wicker baskets (optional).
2. Lift shelf upward.
3. Slide shelf forward (to remove).
4. Rotate shelf upward (or downward) to adjust angle of shelf.

Note: Illustration below shown with end panel removed for illustrative purposes only.

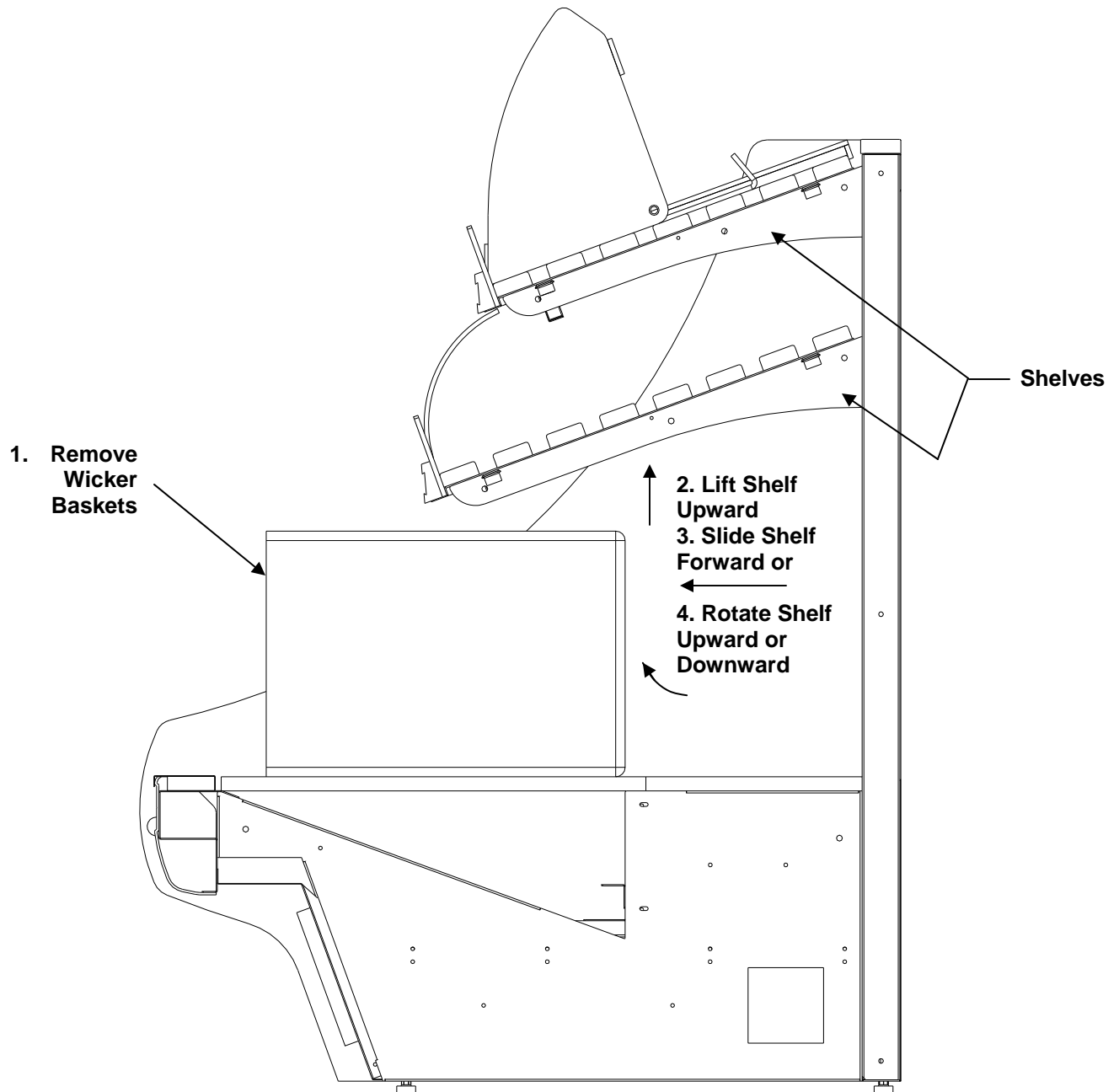

LIGHTS (ACCESS AND REMOVAL)

Light Fixtures

Removal of lamps:

- Grasp lamp firmly and carefully pull downward and out from socket.
- See photo at lower right.

Installation of lamp:

- Align pins with slot.
- Insert pins into socket and push upward into place.
- See photo at lowest right for view of fully installed lamp.

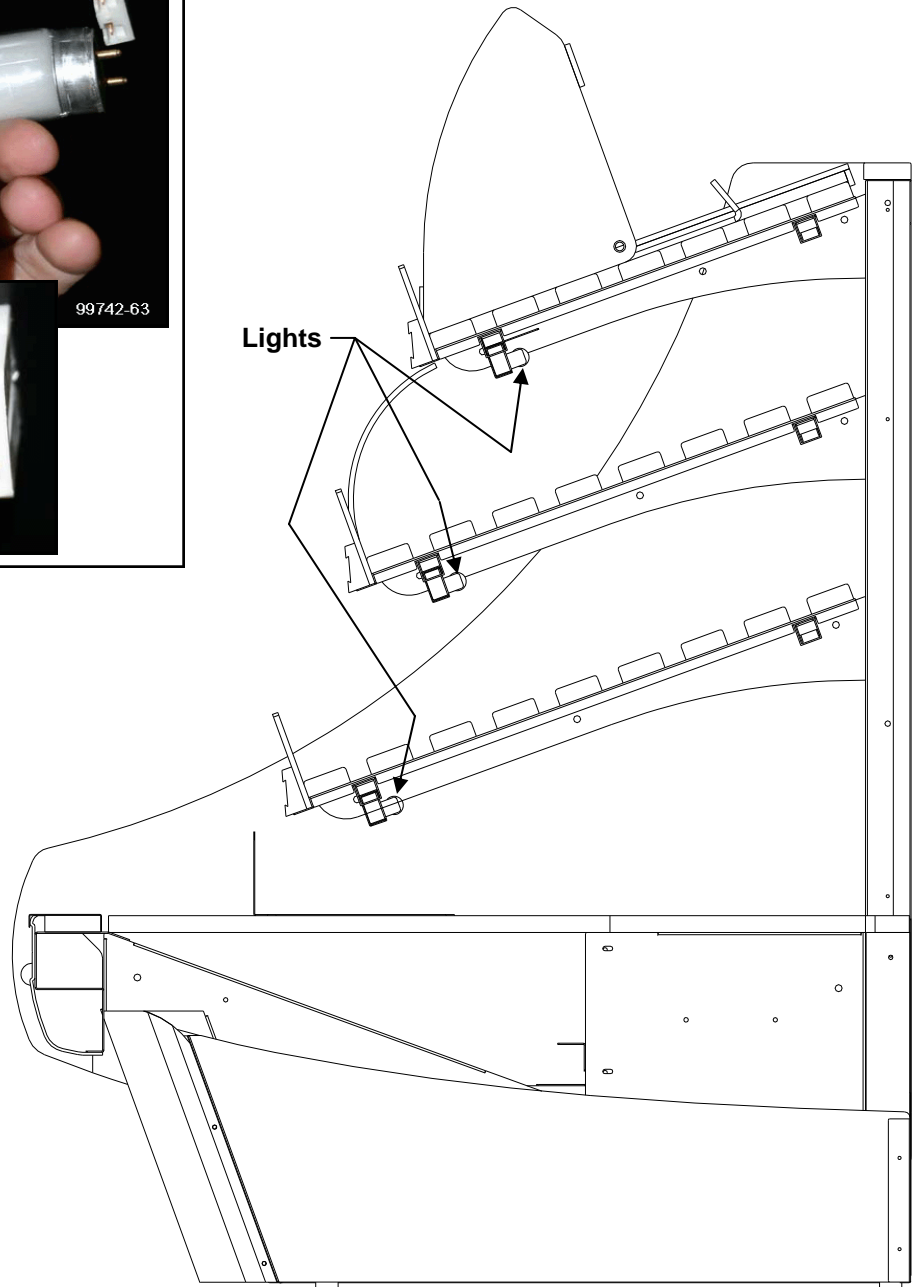

CLEANING SCHEDULE - TO BE PERFORMED BY STORE PERSONNEL

FREQUENCY	INSTRUCTIONS
Weekly	<u>End Panels, Front Panel, Toe-Kick, etc.:</u> Wipe off all surfaces with warm water and mild soap solution and non-abrasive cloth.
Weekly	<u>Shelving:</u> Clean shelves with a household or commercial general cleaner and a soft cloth or paper towel.
Weekly	<u>Wicker Baskets (Optional):</u> Remove Baskets and vacuum away dust and residue. Wipe down with moist cloth dipped in warm water and mild soap solution.
Weekly	<u>Acrylic Storage Bins (Optional):</u> Clean with a warm water and mild soap solution and soft cloth. Never use ammonia-based cleaners on acrylic.
Weekly	<u>Under Case Cleaning:</u> Vacuum under case to remove all dust and dirt that may collect.

TROUBLESHOOTING

CONDITION	TROUBLESHOOTING
Case Lights Are Not Working, continued.	Check for burned out bulbs. Turn lights off & replace.
	Clean dirt and dust from the bulbs to prevent flickering.

Serial Label Location & Information Listed / Technical Information & Service

- Serial labels are located near the electrical access on your case.
- Serial labels contain electrical, temperature & refrigeration information, as well as regulatory standards to which the case conforms.
- For additional technical information and service, see the *TECHNICAL SERVICE* page in this manual for instructions on contacting Structural Concepts' Technical Service Department.
- See images below for samples of both refrigerated and non-refrigerated serial labels.



888 E. Porter Rd · Muskegon, MI 49441

ENCORE[®] MODEL HV74RSS SCROLL
SERIES SERIAL NO.

FOR PARTS AND SERVICE
CALL 1-800-433-9489



3048256
CONFORMS TO UL STD 471
CONFORMS TO NSF STD 7
CERTIFIED TO CAN/CSA
STD C22.2 NO 120

ELECTRICAL RATING	120/1/60 24A
REFRIGERANT	R404A AMOUNT ?? OZ
DESIGN PRESSURE	HIGH 450 LOW 200
MINIMUM CIRCUIT	30A
MAXIMUM OVERCURRENT	30A

SAMPLE ONLY

Super Heat Temp	8-10°F
BTUH Requirements	9,738 BTUH @ 20° F SST
Defrost	6 defrosts per day, 45° F termination, 45 min. failsafe

SAMPLE ONLY

----- Sample Serial Label For Refrigerated Case -----



888 E. Porter Rd · Muskegon, MI 49441

Addenda[®] PC5682 txtRemote
txtSerialNumber

120 VOLTS 60 HZ SINGLE PHASE 1.84AMP

FOR PARTS OR SERVICE CALL
STRUCTURAL CONCEPTS
AT
1-800-433-9489



3048256
CONFORMS TO UL STD 65
CERTIFIED TO CAN/CSA
STD C22.2 NO 120

SAMPLE ONLY

----- Sample Serial Label For Non-Refrigerated Case -----

WARRANTY

All sales by Structural Concepts Corporation (SCC) are subject to the following limited warranty. "Goods" refers to the product or products being sold by SCC.

Warranty; Remedies; Limitations. SCC warrants that if any Goods are found by an authorized representative of SCC not to be of good material or workmanship within one year of the date of shipments SCC will, at its option after inspection by an authorized representative, replace any defective Good or pay the reasonable cost of replacement for any such defective Goods, provided that written notice of the defect is given to SCC within 30 days of the appearance of such defect. If notice is not given within such period, any claim for breach of warranty shall be conclusively deemed to have been waived and SCC shall not be liable under this warranty. If SCC is unable to repair or replace the defective Goods, SCC shall issue a credit to the Purchaser for all or part of the purchase price, as SCC shall determine. The replacement or payment in the manner described above shall be the sole and exclusive remedy of Purchaser for a breach of this warranty. If any Goods are defective or fail to conform to this warranty, SCC will furnish instructions for their disposition. No Goods shall be returned to SCC without its prior consent.

SCC's liability for any defect in the Goods shall not exceed the purchase price of the Goods. SCC SHALL HAVE NO LIABILITY TO PURCHASE FOR CONSEQUENTIAL DAMAGES OF ANY KIND WHATSOEVER, INCLUDING, BUT NOT LIMITED TO, PERSONAL INJURY, PROPERTY DAMAGE, LOST PROFITS, OR OTHER ECONOMIC INJURY DUE TO ANY DEFECT IN THE GOODS OR ANY BREACH OF SCC, SCC SHALL NOT BE LIABLE TO THE PURCHASER IN TORT FOR ANY NEGLIGENT DESIGN OR MANUFACTURE OF THE GOODS, OR FOR THE OMISSION OF ANY WARNING THEREFROM.

SCC shall have no obligation or liability under this warranty for claims arising from any other party's (including Purchaser's) negligence or misuse of the Goods or environmental conditions. This warranty does not apply to any claim or damage arising for or caused by improper storage, handling, installation, maintenance, or from fire, flood, accidents, structural defects, building settlement or movement, acts of God, or other causes beyond SCC's control.

Except as expressly stated herein, SCC makes no warranty, express, implied, statutory or otherwise as to any parts or goods not manufactured by SCC. SCC shall warrant such parts or Goods only (I) against such defects, (II) for such periods of time, and (III) with such remedies, as are expressly warranted by the manufacturer of such parts or Goods. Notwithstanding the foregoing, any warranty with respect to such parts or Goods and any remedies available as a result of a breach thereof shall be subject to all of the procedures, limitations, and exclusions set forth herein.

THE WARRANTIES HEREIN ARE IN LIEU OF ALL WARRANTIES, EXPRESS, IMPLIED, STATUTORY, OR OTHERWISE. IN PARTICULAR, SCC MAKES NO WARRANTY OF MERCHANTABILITY OR FITNESS FOR A PARTICULAR PURPOSE.

No representative, agent or dealer of SCC has authority to modify, expand, or extend this Warranty, to waive any of the limitations or exclusions, or to make any different or additional warranties with respect to Goods.

Period of Limitations. No claim, suit or other proceeding may be brought by Purchaser for any breach of the foregoing warranty or this Agreement by SCC or in any way arising out of this Agreement or relating to the Goods after one year from the date of the breach. In the interpretation of this limitation on action for a breach by SCC, it is expressly agreed that there are no warranties of future performance of the goods that would extend that period of limitation herein contained for bringing an action.

Indemnifications. Purchaser agrees to indemnify, hold harmless, and defend SCC if so requested, from any and all liabilities, as defined herein, suffered, or incurred by SCC as a result of, or in connection with, any act, omission, or use of the Goods by Purchaser, its employees or customers, or any breach of this Agreement by Purchaser. Liabilities shall include all costs, claims, damages, judgments, and expenses (including reasonable attorney fees and costs).

Remedies of SCC. SCC's rights and remedies shall be cumulative and may be exercised from time to time. In a proceeding or action relating to the breach of this Agreement by Purchaser, Purchaser shall reimburse SCC for reasonable costs and attorney's fees incurred by SCC. No waiver by SCC of any breach of Purchaser shall be effective unless in writing nor operate as a waiver of any other breach of the same term thereafter. SCC shall not lose any right because it has not exercised it in the past.

Applicable Law. This Agreement is made in Michigan and shall be governed by and interpreted according to Michigan law. Any lawsuit arising out of this Agreement or the Goods may be handled by a federal or state court whose district includes Muskegon County, Michigan, and Purchaser consents that such court shall have personal jurisdiction over Purchaser.

Miscellaneous. If any provision of this Agreement is found to be invalid or unenforceable under any law, the provision shall be ineffective to that extent and for the duration of the illegality, but the remaining provisions shall be unaffected. Purchaser shall not assign any of its rights nor delegate any of its obligations under this Agreement without prior written consent of SCC. This Agreement shall be binding upon and inure to the benefit of SCC and Purchaser and each of their legal representatives, successors and assigns.

SCC warrants its products to be free of defects in materials and workmanship under normal use and service for a period of one (1) year from the date of delivery.

This warranty is extended only to the original purchaser for use of the Goods. It does not cover normal wear parts such as plastic tongs, tong holders, tong cables, bag holders, or acrylic dividers.

General Conditions. All service labor and/or parts charges are subject to approval by SCC. Contact the Customer Service Department in writing or call 231-798-8888.

All claims must contain the following information: (1) the model and serial code number of the equipment; (2) the date and place of installation; (3) the name and address of the agency which performed the installation; (4) the date of the equipment failure; and (5) a complete description of the equipment failure and all circumstances relating to that failure.

Once the claim has been determined to be a true warranty claim by SCC's Customer Service Department, the following procedure will be taken: (1) replacement parts will be sent at no charge from SCC on a freight prepaid basis; (2) reimbursement for service labor will be paid if the following conditions have been met— (a) prior approval of service agency was awarded from the Customer Service Department; and (b) an itemized statement of all labor charges incurred is received by the Customer Service Department. The cost of the service labor reimbursement will be based on straight time rates and reasonable time for the repair of the defect.

If problems occur with any compressor, notify SCC's Customer Service Department immediately. Any attempt to repair or alter the unit without prior consent from the Customer Service Department will render any warranty claim null and void. This warranty and protection plan does not apply to any condensing unit or any part thereof which has been subject to accident, negligence, misuse, or abuse, or which has not been operated in accordance with the manufacturer's recommendations or if the serial number of the unit has been altered, defaced, or removed.

Limit of Liability. The limit of liability of SCC toward the exchange cost of the original condensing unit, F.O.B. SCC, Norton Shores, MI, of each motor-compressor assembly replaced during the warranty shall not exceed manufacturer's current established wholesaler's exchange price and in no case shall the labor of removing or replacing the motor-compressor or parts thereof be the responsibility of SCC.

**STRUCTURAL CONCEPTS CORPORATION
TECHNICAL SERVICE DEPARTMENT
1.800.433.9489**